



Driving Future Leadership

Q4 & FY26 INVESTOR PRESENTATION

May 2026

Safe Harbor

This presentation has been prepared by and is the sole responsibility of **Talbros Automotive Components Limited** (the “Company”). By accessing this presentation, you are agreeing to be bound by the trailing restrictions.

This presentation does not constitute or form part of any offer or invitation or inducement to sell or issue, or any solicitation of any offer or recommendation to purchase or subscribe for, any securities of the Company, nor shall it or any part of it or the fact of its distribution form the basis of, or be relied on in connection with, any contract or commitment thereof. In particular, this presentation is not intended to be a prospectus or offer document under the applicable laws of any jurisdiction, including India. No representation or warranty, express or implied, is made as to, and no reliance should be placed on, the fairness, accuracy, completeness or correctness of the information or opinions contained in this presentation. Such information and opinions are in all events not current after the date of this presentation. There is no obligation to update, modify or amend this communication or to otherwise notify the recipient if the information, opinion, projection, forecast or estimate set forth herein, changes or subsequently becomes inaccurate.

Certain statements contained in this presentation that are not statements of historical fact constitute “forward-looking statements.” You can generally identify forward looking statements by terminology such as “aim”, “anticipate”, “believe”, “continue”, “could”, “estimate”, “expect”, “intend”, “may”, “objective”, “goal”, “plan”, “potential”, “project”, “pursue”, “shall”, “should”, “will”, “would”, or other words or phrases of similar import. These forward-looking statements involve known and unknown risks, uncertainties, assumptions and other factors that may cause the Company’s actual results, performance or achievements to be materially different from any future results, performance or achievements expressed or implied by such forward-looking statements or other projections. Important factors that could cause actual results, performance or achievements to differ materially include, among others: (a) our ability to successfully implement our strategy, (b) our growth and expansion plans, (c) changes in regulatory norms applicable to the Company, (d) technological changes, (e) investment income, (f) cash flow projections, and (g) other risks.

This presentation is for general information purposes only, without regard to any specific objectives, financial situations or informational needs of any particular person. The Company may alter, modify or otherwise change in any manner the content of this presentation, without obligation to notify any person of such change or changes.



Q4 & FY26 Financial Highlights

Talbros Automotive Components Limited (TACL) - Group

Group Turnover: ₹ 1,383 Crs. in FY26 | ₹. 1,261 Crs. in FY25 ▲ 10%

Sealing Division

Total Income

₹ 595 Crs. | ₹ 556 Crs. ▲ 7%
FY26 | FY25

- Gaskets
- Heat shields

Marelli Division (50% JV)

Total Income

₹ 346 Crs. | ₹ 285 Crs. ▲ 21%
FY26 | FY25

- Chassis Components

Marelli Talbros Chassis Systems Pvt Ltd

Forgings Division

Total Income

₹ 295 Crs. | ₹ 290 Crs. ▲ 2%
FY26 | FY25

- Forging Components

Marugo Division (50% JV)

Total Income

₹ 147 Crs. | ₹ 130 Crs. ▲ 13%
FY26 | FY25

- Anti Vibration Products
- Hoses

Talbros Marugo Rubber Pvt Ltd

TACL Standalone

Q4 & FY26 Consolidated Financial Highlights

Q4 FY26 vs Q4 FY25

Total Income from Operations [^]

₹ 241 Crs.
(+ 14% YoY)

EBITDA[^] / EBITDA Margin (%)

₹ 45 Crs. / 18.7%
(+13% YoY) / (-20 bps YoY)

Profit After Tax / PAT Margin (%)

₹ 32 Crs. / 13.1%
(+ 19% YoY) / (+50 bps YoY)

FY26 vs FY25

Total Income from Operations[^]

₹ 889 Crs.
(+ 5% YoY)

EBITDA[^] / EBITDA Margin (%)

₹ 155 Crs. / 17.5%
(+ 5% YoY)

Profit After Tax / PAT Margin (%)

₹ 104 Crs. / 11.7%
(+10% YoY) / (+50 bps YoY)

Return on Capital Employed (RoCE)*

17.9%

Debt / Equity* (x)

0.10x

*As at March 2026

[^]Includes Other Income

Q4 & FY26 Consolidated Financial Highlights

Q4 FY26 vs Q4 FY25

	Gasket & Heat Shield (52% of Revenue) (48% - Gaskets) (4% - Heat shields)	Forgings (24% of Revenue)	MTCS (17% of Revenue)	TMR (7% of Revenue)
Revenue	₹164.4 Crs. +15% YoY	₹76.2 Crs. +11% YoY	₹103.5 Crs. +35% YoY	₹42.2 Crs. +24% YoY
EBITDA	₹31.3 Crs. +18% YoY	₹13.6 Crs. +3% YoY	₹18.2 Crs. +32% YoY	₹5.7 Crs. +28% YoY

FY26 vs FY25

	Gasket & Heat Shield (52% of Revenue) (48% - Gaskets) (4% - Heat shields)	Forgings (26% of Revenue)	MTCS (15% of Revenue)	TMR (7% of Revenue)
Revenue	₹595.0 Crs. +7% YoY	₹294.9 Crs. +1.83% YoY	₹346.0 Crs. +21% YoY	₹146.8 Crs. +13% YoY
EBITDA	₹105.2 Crs. +9% YoY	₹51.3 Crs. -2% YoY	₹62.0 Crs. +35% YoY	₹18.8 Crs. +14% YoY

Appointment of CEO



Mr. Ashish Gupta has been appointed as the CEO of Talbros Automotive Components Limited

- Mr. Ashish Gupta is a highly accomplished professional with over 35 years of leadership experience in driving business operations across diverse industries.
- He holds a bachelor's degree in production engineering and is recognized for his hands-on leadership style, strategic clarity, and strong focus on quality, performance, and stakeholder value.
- He has held senior leadership roles in India and overseas, including assignments in Germany and the CIS region, and has been involved in setting up and scaling automotive manufacturing operations.
- He has worked as the Chief Executive Officer of Marelli Talbros Chassis Systems Pvt. Ltd., a leading automotive components joint venture between Talbros Automotive Components and Marelli Suspension Systems, Italy SpA.

New Order Update

TACL along with its JV's has received orders worth over ₹ 1,000 crores

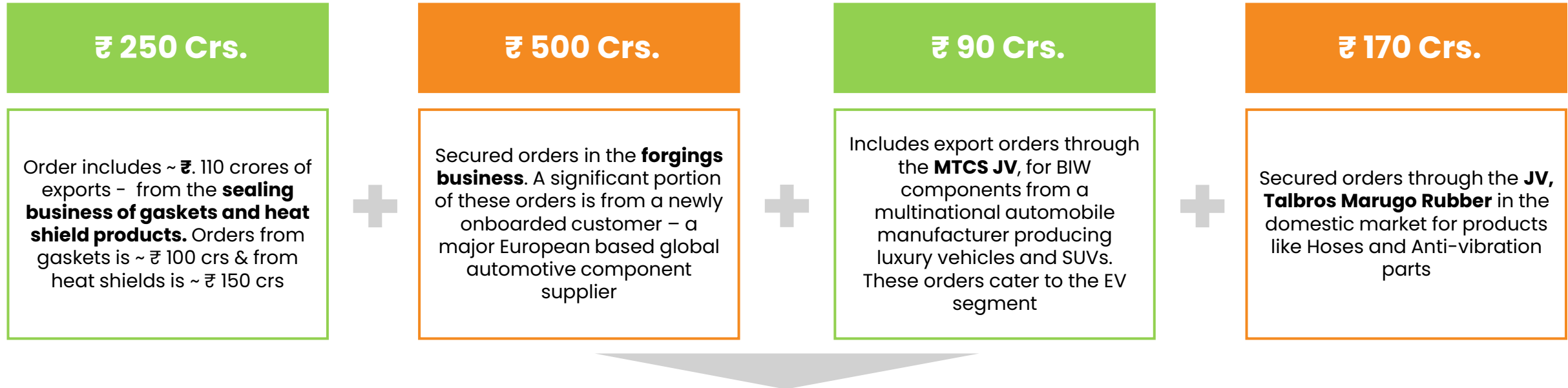

- ✓ **The company is deepening its footprint in a highly competitive and demanding market of Europe.** This expansion not only demonstrates the company's capability to meet global benchmarks but also positions it as a reliable supplier within the European automotive ecosystem. **As a result, the company is gaining market share in this region.**
- ✓ These orders are to be executed over the period of next 5 years
- ✓ The commercialization for these products will start from FY27
- ✓ These orders include **~Rs. 100 crores** order received for **EV segment**
- ✓ These orders include **~Rs. 700 crores** order received for **Exports segment**

Consolidated P&L Statement

Particulars (Rs. in crores)	Q4 FY26	Q4 FY25	Y-o-Y	FY26	FY25	Y-o-Y
Revenue from Operations	236.5	205.9	15%	870.0	827.1	5%
Other Income	4.1	5.1		18.5	17.7	
Total Revenue from Operation	240.6	210.9	14%	888.5	844.7	5%
Raw Material	120.7	97.5		451.0	429.4	
Employee Cost	24.5	23.6		99.5	92.3	
Other Expenses	50.5	50.1		183.0	175.9	
EBITDA	44.9	39.8	13%	155.1	147.3	5%
EBITDA Margin	18.7%	18.9%		17.4%	17.4%	
Depreciation	8.3	7.8		32.7	31.9	
EBIT	36.6	32.0	14%	122.4	115.4	6%
EBIT Margin	15.2%	15.2%		13.8%	13.7%	
Finance cost	3.2	3.7		13.2	13.7	
Share of Profit from JVs	6.6	5.3		21.7	17.7	
Profit before Tax (Before Exceptional Items)	40.0	33.6	19%	130.9	119.4	10%
Tax	8.4	7.0		26.8	25.0	
Profit After Tax (Before Exceptional Items)	31.6	26.6	19%	104.1	94.4	10%
PAT Margin %	13.1%	12.6%		11.7%	11.2%	

Diversified Revenue Mix

Breakup (Type of Market)*

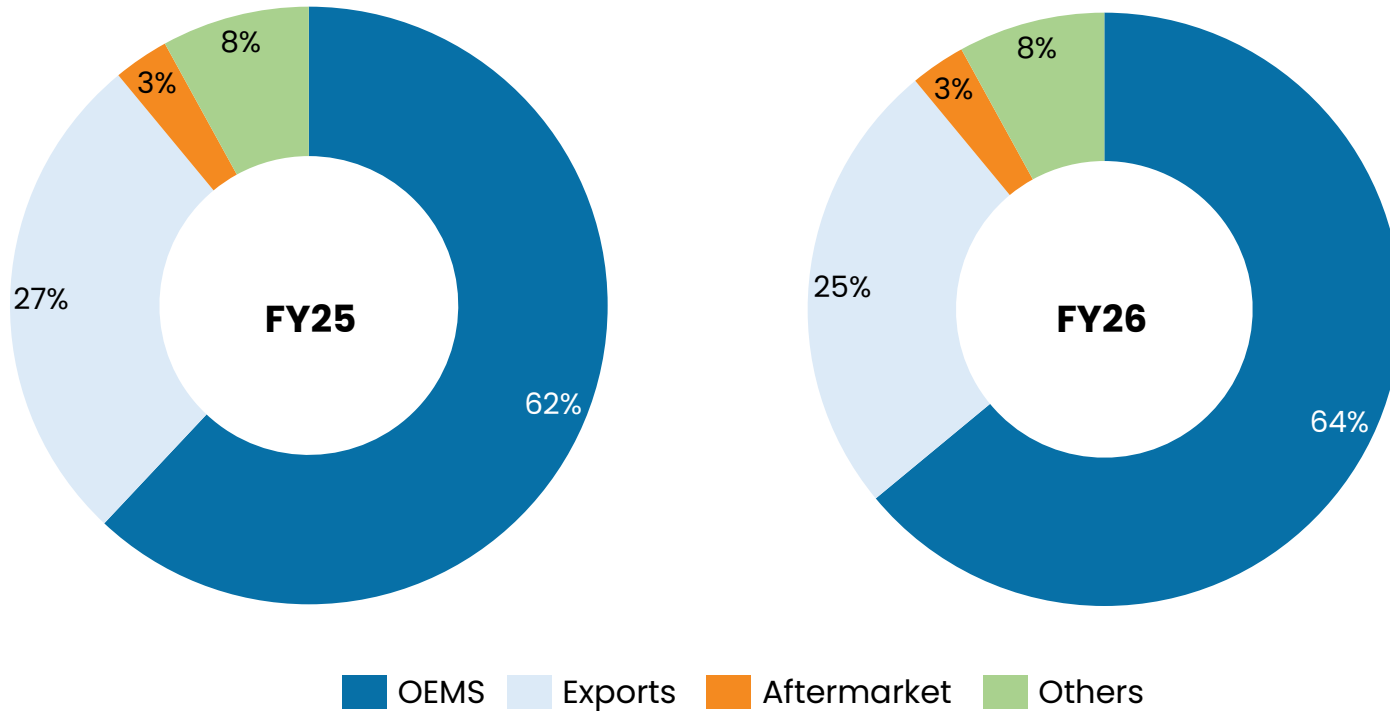

Domestic Breakup (By Market Type)

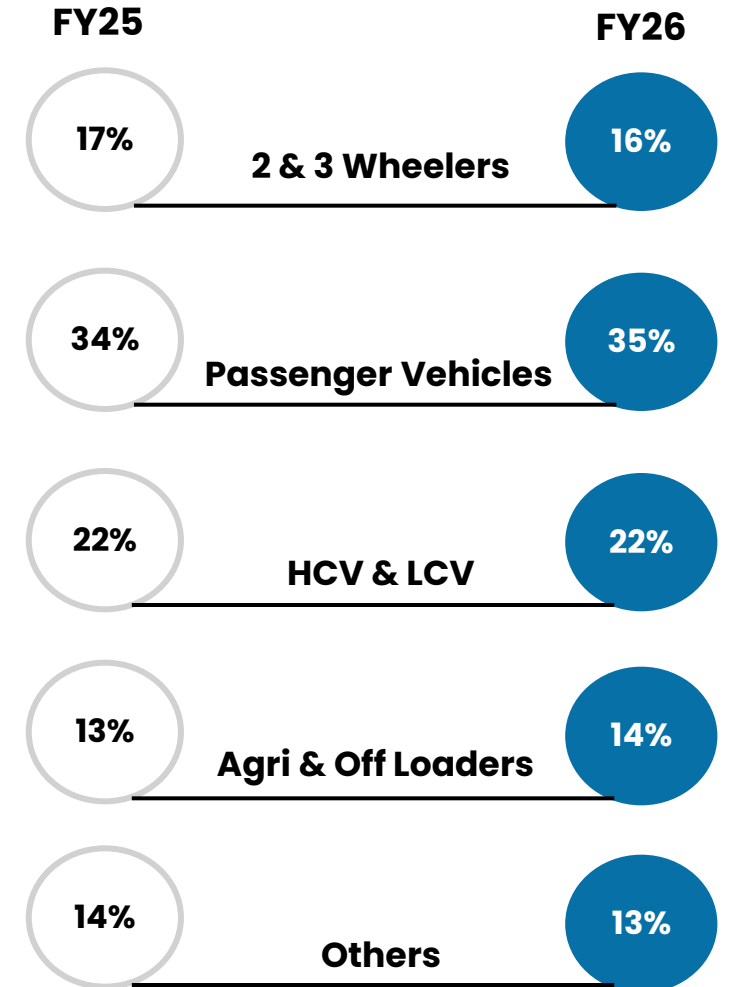

*Proportionate share of JV

Export Profile

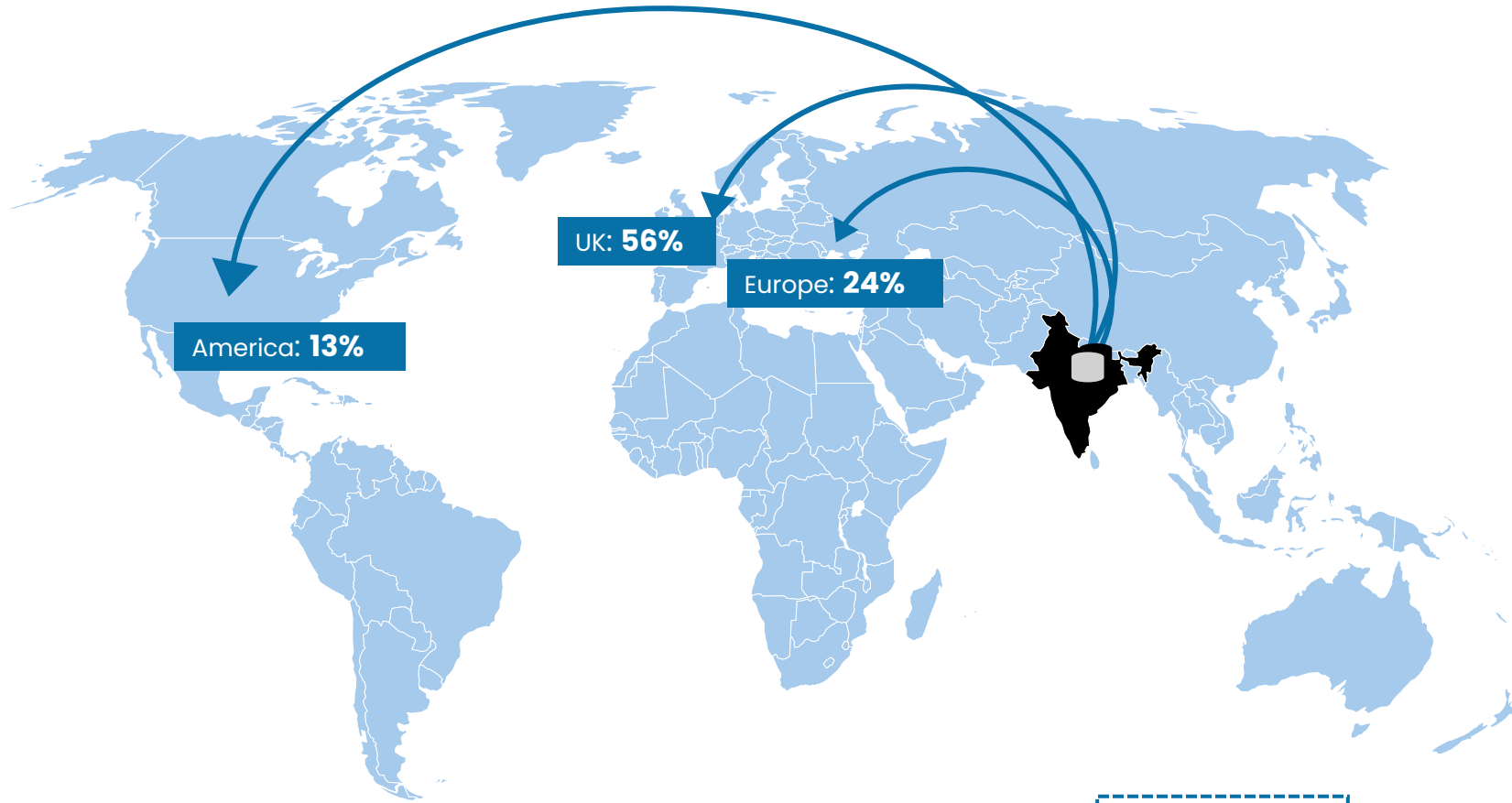

Well-Positioned to Capitalise on Global OEM Sourcing Shifts

- ✓ Diversified exports with Europe & UK comprising of ~80%
- ✓ Structural challenges in Europe’s auto industry—weak OEM and Tier-1 balance sheets—are driving supplier consolidation and sourcing shifts
- ✓ Global OEMs reducing China dependence are accelerating supply-chain realignments toward reliable alternate geographies
- ✓ Talbros is well positioned to benefit, leveraging strong engineering, cost competitiveness, and execution capabilities
- ✓ Export order book continues to strengthen, supported by deeper global OEM relationships
- ✓ ₹700 Crs of recent export order wins, including from a large European auto OEM, provide strong medium-term visibility

Export Contribution (%)

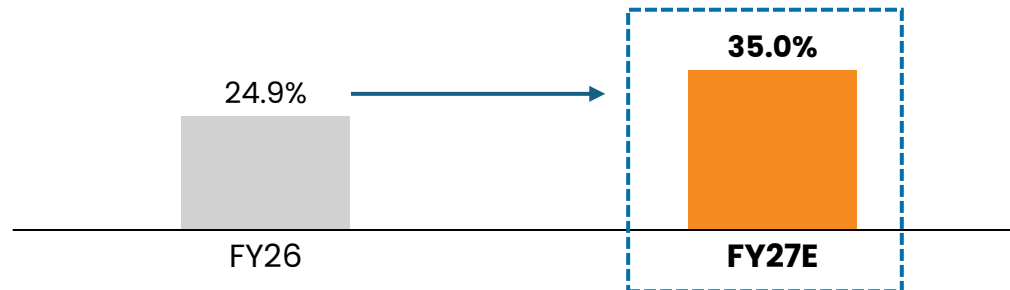

Diversified Customer Base

FY26

Top 10 customers

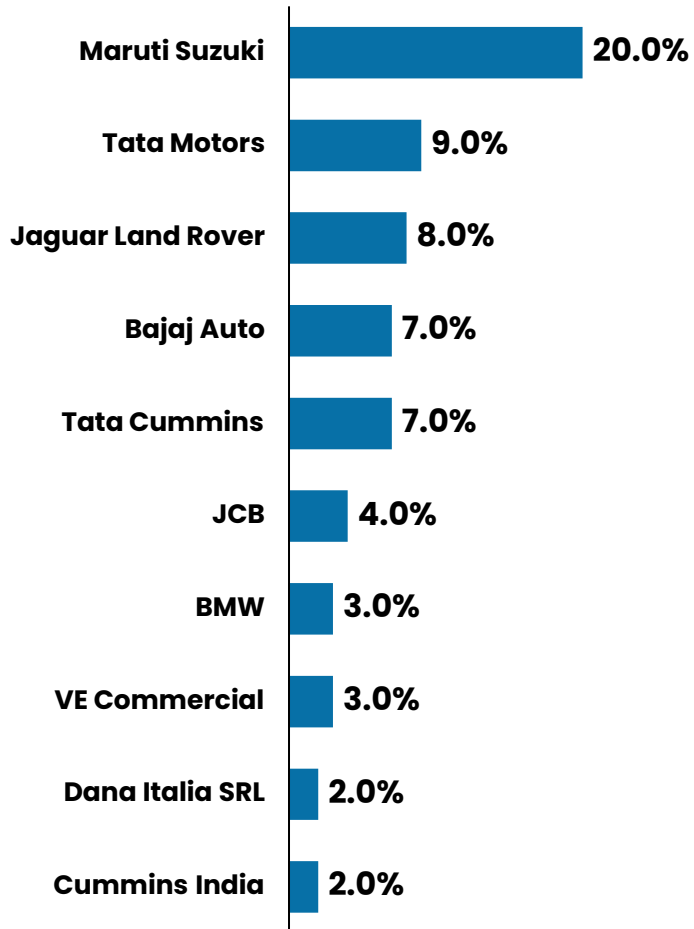

Hedged Customer Base

2 Wheeler



Passenger



HCV/LCV



DAIMLER



Agri & Off Loader



Business Verticals

Talbros At a Glance

<p>60+ YEARS OF EXPERIENCE</p> <p>Deep expertise in auto component manufacturing</p>	<p>5 PRODUCT VERTICALS</p> <p>Gaskets, Heat Shields, Forgings, Suspension, Anti-vibration & Hoses</p>	<p>Diversified AUTO COMPONENT PLAYER</p> <p>Two Wheelers, PVs, CVs, Off-Highway & Farm Equipment</p>
<p>EV Ready</p> <p>Supplying major OEMs globally in the electric vehicle transition</p>	<p>30+ OEM CLIENTS</p> <p>Wide base spanning products and geographies worldwide</p>	<p>2 GLOBAL JVS</p> <p>International technology tie-ups for best-in-class products</p>

*One of the
**Most
Hedged**
Auto
Component
Players*

Gasket & Heat Shields Business

Market Leader

- ✓ ~50% Market share in Gaskets **3x** the nearest competitor
- ✓ Market Leader in – Two-Wheeler, Agri & Off Loaders, HCV & LCV segment
- ✓ **Single Source** Supplier for **5** of our customers

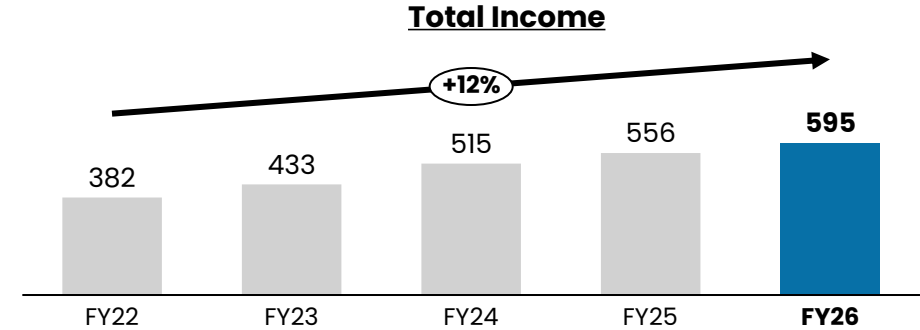

Key Customers



Segment Wise Breakup

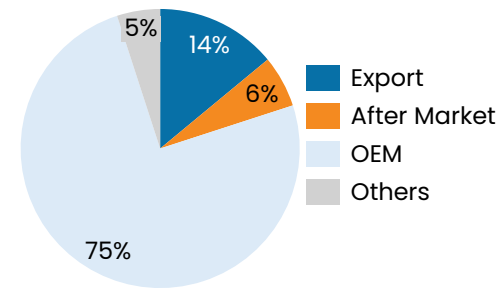

FY26 Breakup

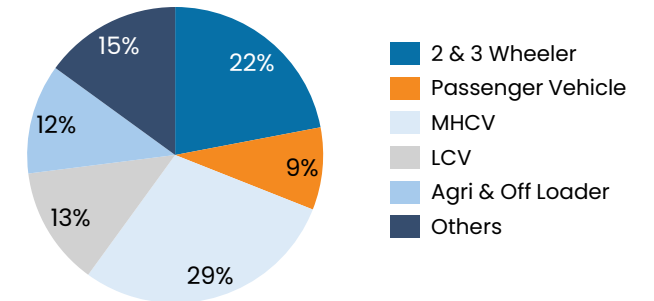

Heat Shields

- ✓ Signed up exclusive contract with SANWA for Light Weight Aluminium Heat Shields which is used for automotive applications specially in PV segment and is a futuristic product technology
- ✓ Value added features like Noise Reduction, Emission Control, Heat Insulation at challenging temperatures and is a widely used on new generation engines including Hybrid and EV's
- ✓ Revenue from **heat shield in FY26 stands ₹ 57.66 Crs.** and from **EV in FY26 Stands at ₹ 0.68 Crs.**

Forgings Business

One Stop Solution Provider

- ✓ One stop solution for **Hot Forging** (750 to 2,500 Ton Press)
- ✓ **Strong presence in Overseas Market & Supplier to Top Tier I companies**
- ✓ **One Stop Solution** for Die Design, Machine parts and Heat treatment (Normalizing and Carburizing)
- ✓ Revenue from EV in forging division in FY26 Stands at **₹ 14.86 Crs.**

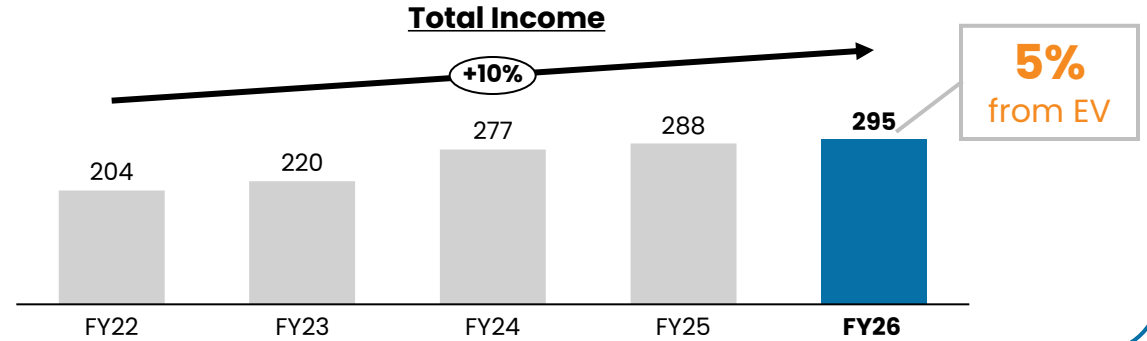

Key Customers



Segment Wise Breakup

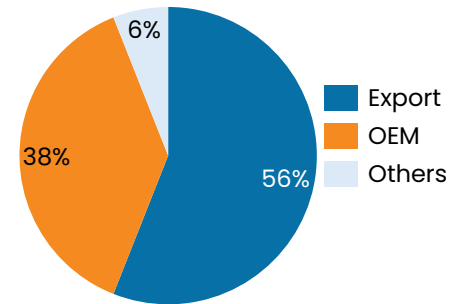

FY26 Breakup

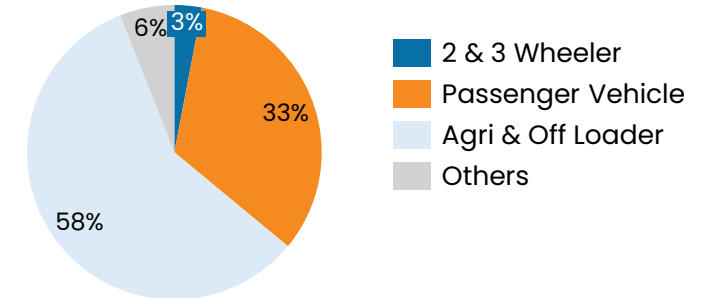

Product Types:

King Pins

Dump End

Gear Blanks

Retaining Plate

Housing & Yoke Shafts

Companion Flange

Strong Global Partnerships – Joint Ventures (MTCS)



Marelli Talbros Chassis Systems Pvt. Ltd. (MTC)

- ✓ **Marelli Corporation** - A global automotive supplier with annual revenue of over € 6 Bn
- ✓ 50:50 partnership commenced production in April 2012
- ✓ 100% Sales to OEMs
- ✓ Significant share of Control Arms business from Maruti Suzuki and Tata
- ✓ **90%+** of the revenue in this JV comes from the PV segment

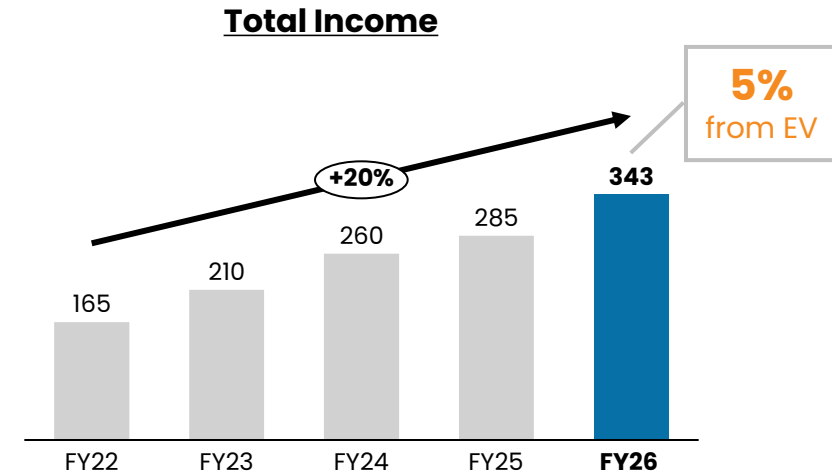

Products

Control Arms

Front Axle

Rear Axle

Key Customers



Revenue Split

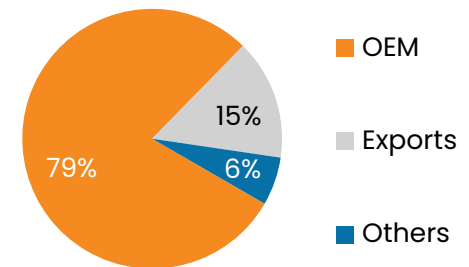

Strong Global Partnerships – Joint Ventures (TMR)



Talbros Marugo Rubber Pvt. Ltd. (TMR)

- ✓ **Marugo Rubber Industries Ltd (Japan)** - Global leader in supply of Anti-Vibration Product and Hoses
- ✓ 50:50 partnership commenced production in February 2013
- ✓ 100% Sales to OEMs predominantly Maruti Suzuki
- ✓ **~90%** of the revenue in this JV comes from the PV segment and **8%** from CV segment

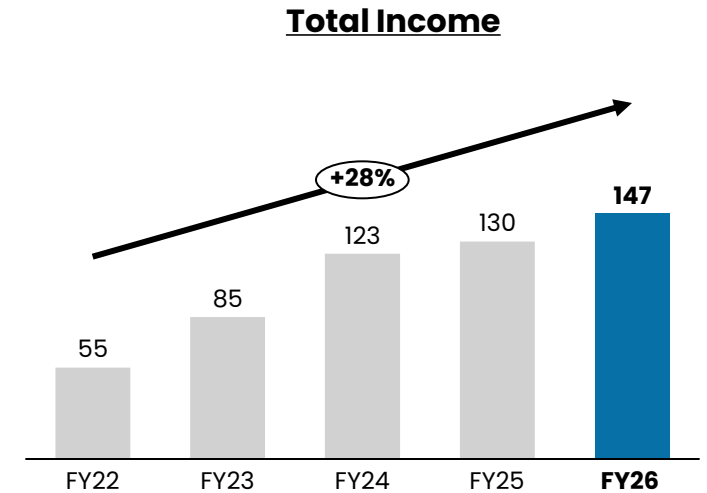

Products

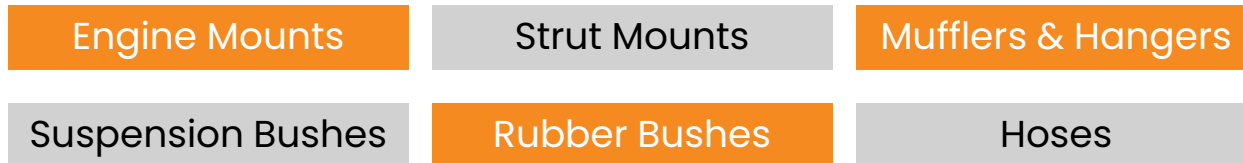

Key Customers



Revenue Split

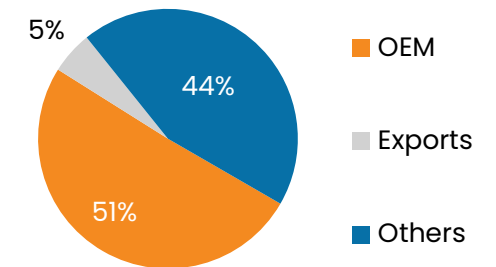

Lohum Talbros Carbon Pvt. Limited – Joint Venture

LOHUM TALBROS CARBON PVT. LTD



Talbros Automotive Components Ltd

49%



Where Critical meets *Infinite*

Lohum Cleantech Private Ltd

51%

Product Overview

- ✓ **Recovered Carbon Black (rCB):** Carbon black is a fine black powder used to strengthen rubber (also used as a pigment in inks and coatings). rCB is recycled carbon black and can substitute for virgin carbon black.
- ✓ **Devulcanized Rubber:** Natural/synthetic rubber goes through vulcanization to harden. To reuse or recycle rubber (e.g. from tyres), one needs to devulcanize it (break the carbon-sulphur bonds).

Industry Overview

- ✓ Virgin carbon black is a **~\$27 B** market; rCB is a **~\$1.8 B** high-growth subset growing at **+35% CAGR**
- ✓ Devulcanized rubber is **~\$3.5 B market** globally and rising with OEM sustainability targets growing at **+10% CAGR**
- ✓ Early conversations indicate ~20% substitution potential in compounds when quality clears the bar

Scope of Business

- ✓ The JV is a technology led entry into a large, ESG-advantaged market, with a partner who has technology for the product line.
- ✓ Business to be commenced from July 2026 onwards
- ✓ Subject to lock-in, the non-selling party has Right of First Refusal on the sale of other party's shareholding

Funding Plans

- ✓ Equity funding for the 1st year is ₹ 20 Crs. out of which Talbros' commitment will be at 49% of that (**i.e. ₹ 9.95 Crs.**)

Capex Plans

Capacity Utilization (FY26)

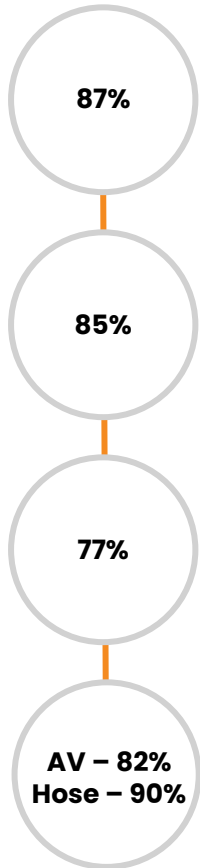

Additional Capex to reach revenues in FY27e

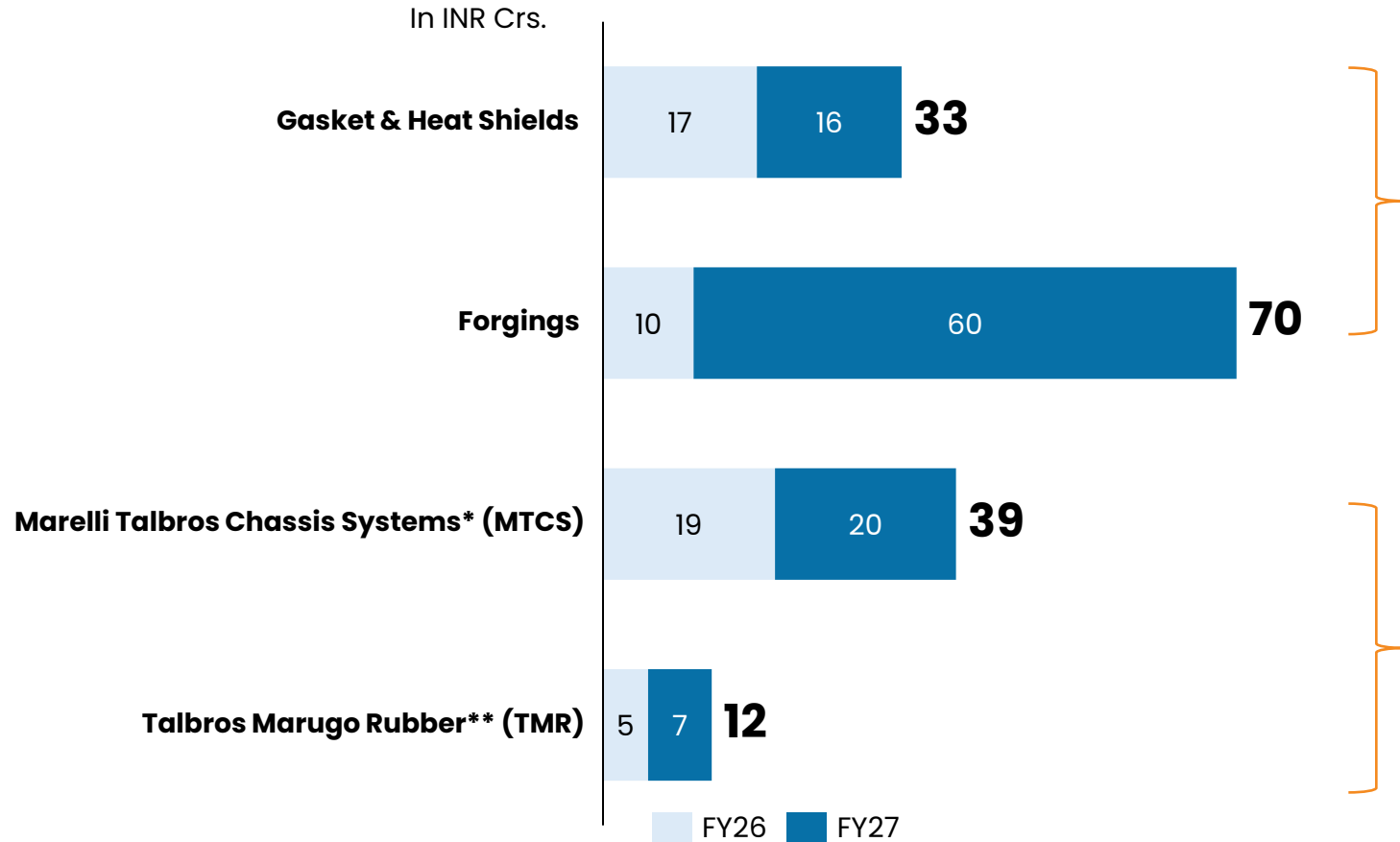

To be funded by Internal Accruals & some borrowings

These amounts will be funded by respective Companies through internal accruals and some borrowings

Total Capex

✓ FY26: **INR 51 Crs.**

✓ FY27: **INR 103 Crs.**

* MTCS is a 50% Joint Venture with Marelli Suspension Systems SpA

** TMR is a 50% Joint Venture with Marugo Rubber

Product Profile

Product Profile – Gasket Division (1/4)

Gasket in 2 Wheelers

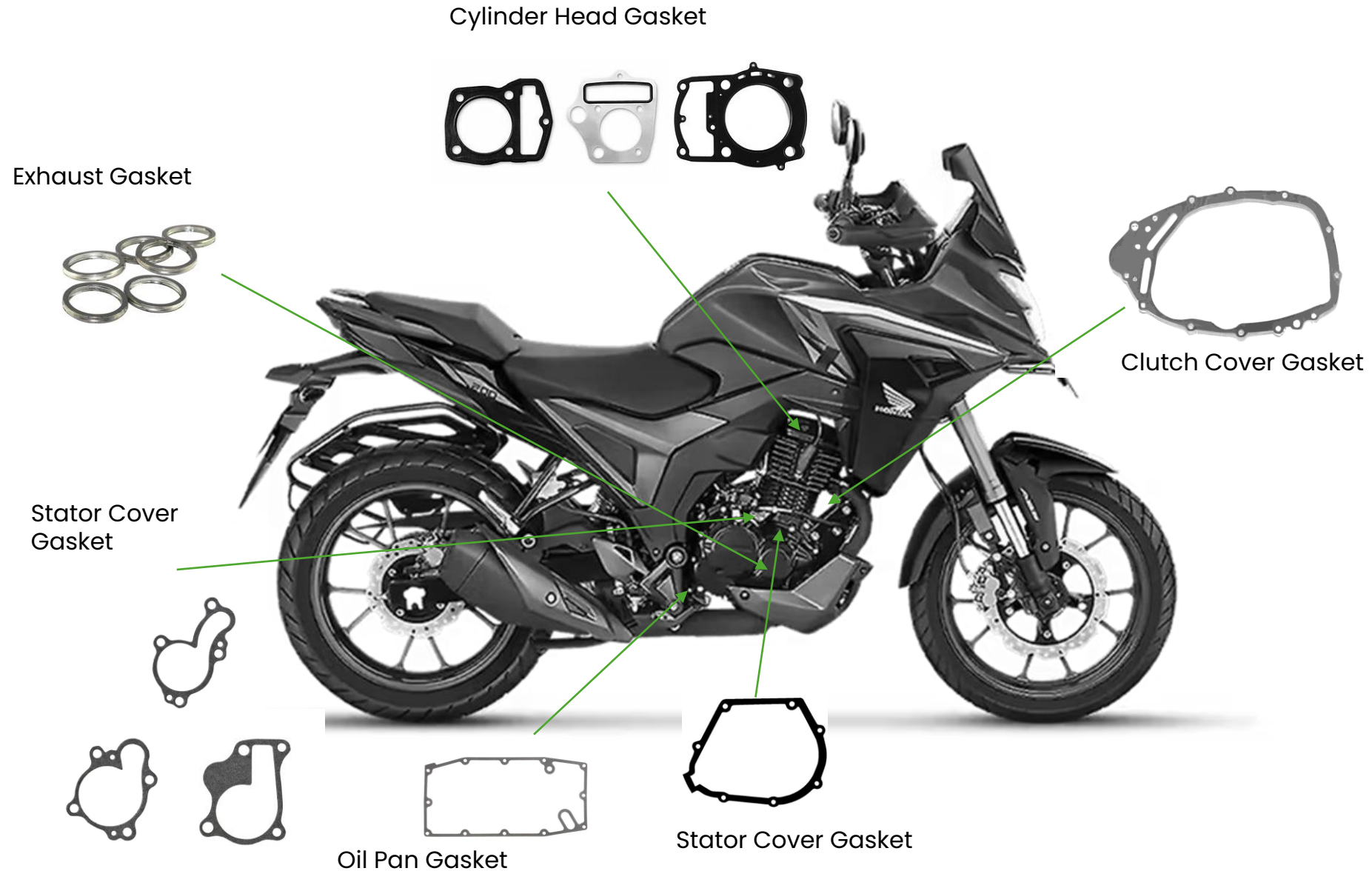

Product Profile – Gasket Division (2/4)

Gasket & Heat shield in Passenger Car

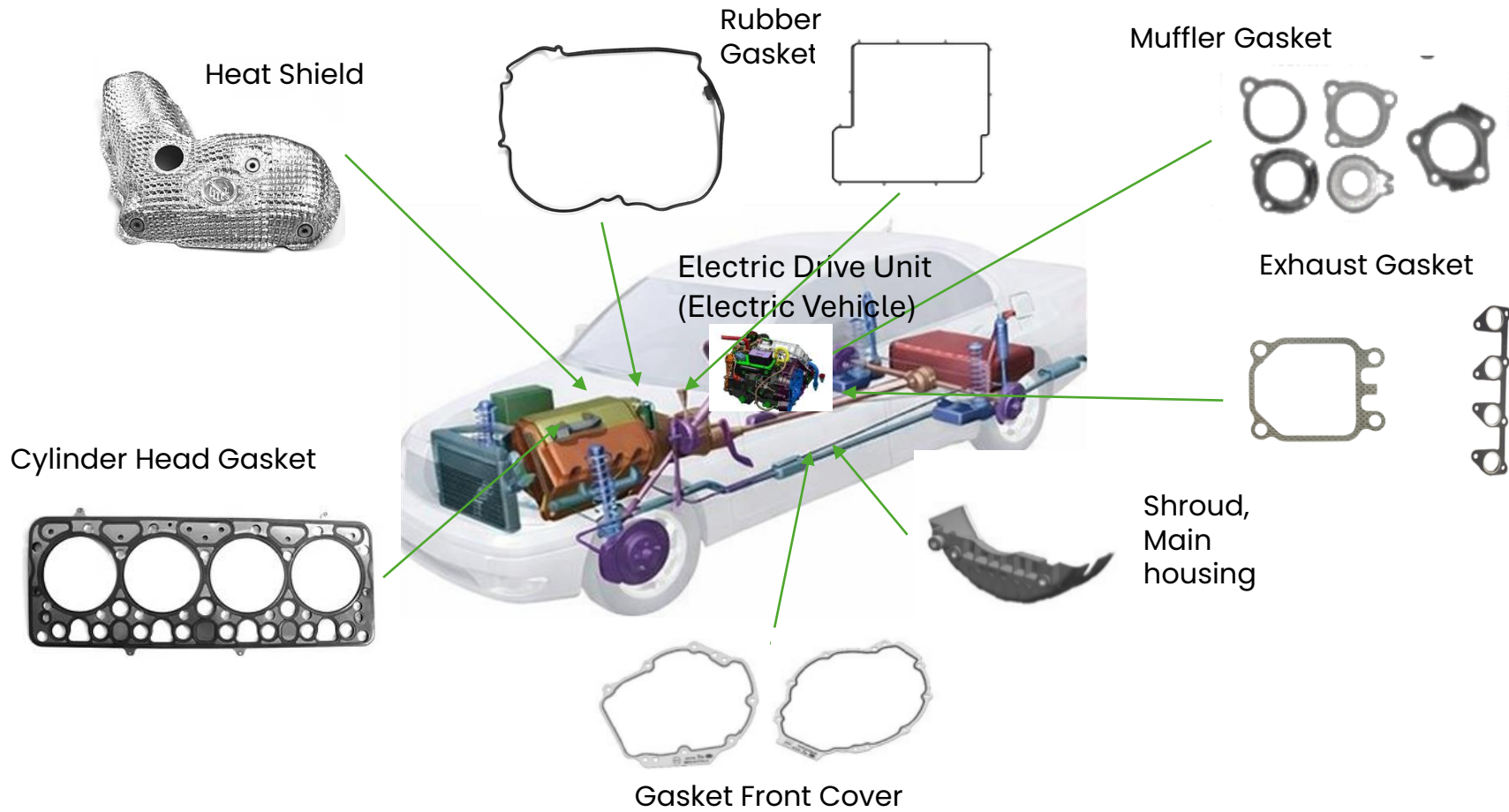

Product Profile – Gasket Division (3/4)

Gasket in Tractor Engine

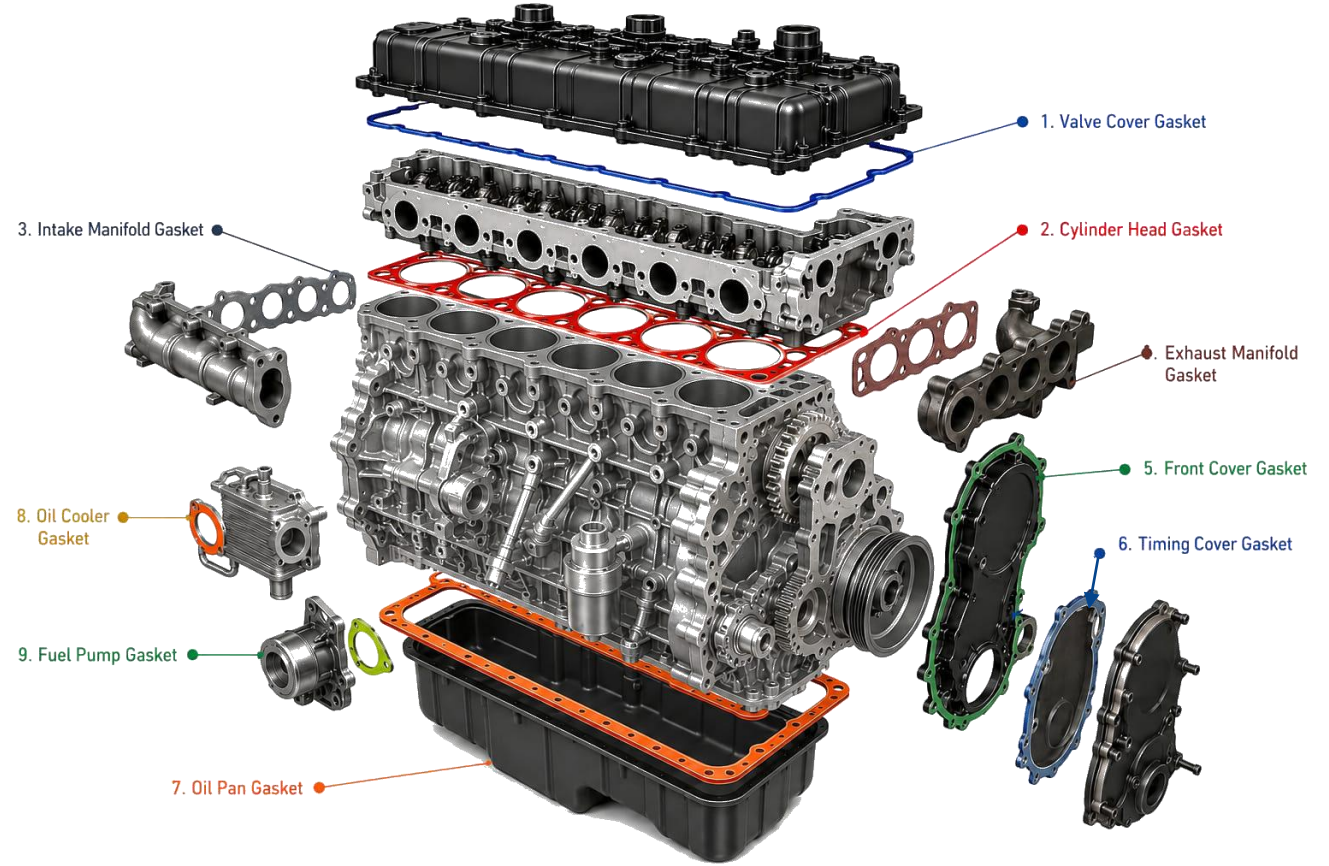
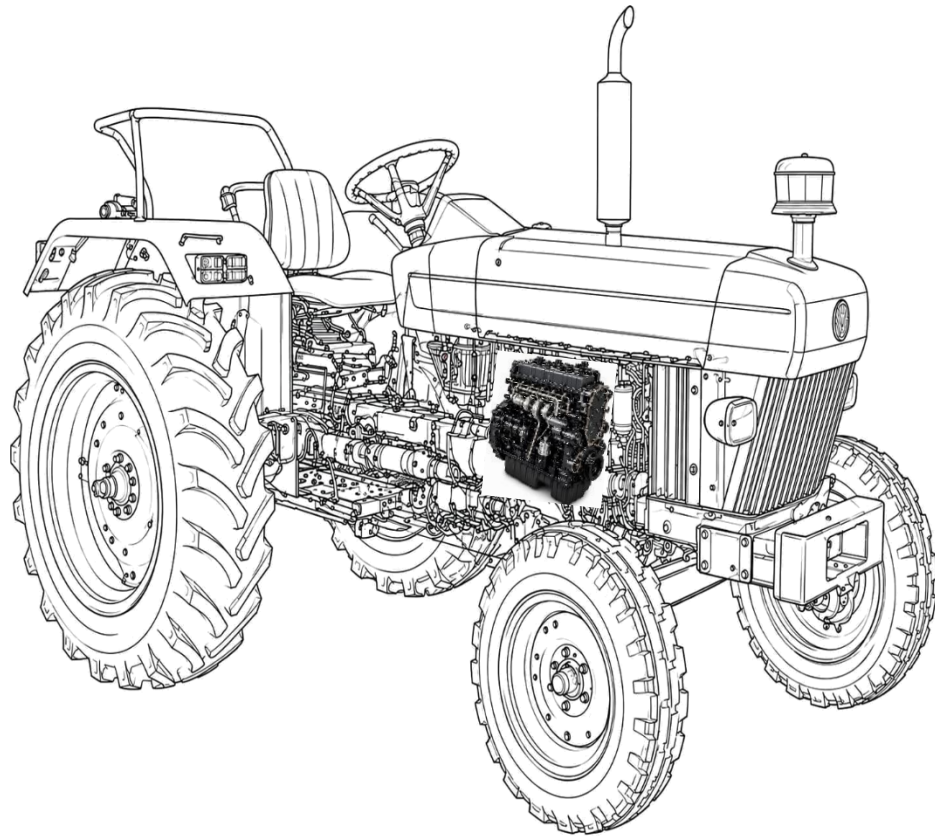

Product Profile – Gasket Division (4/4)

Gasket & Heatshield in Truck

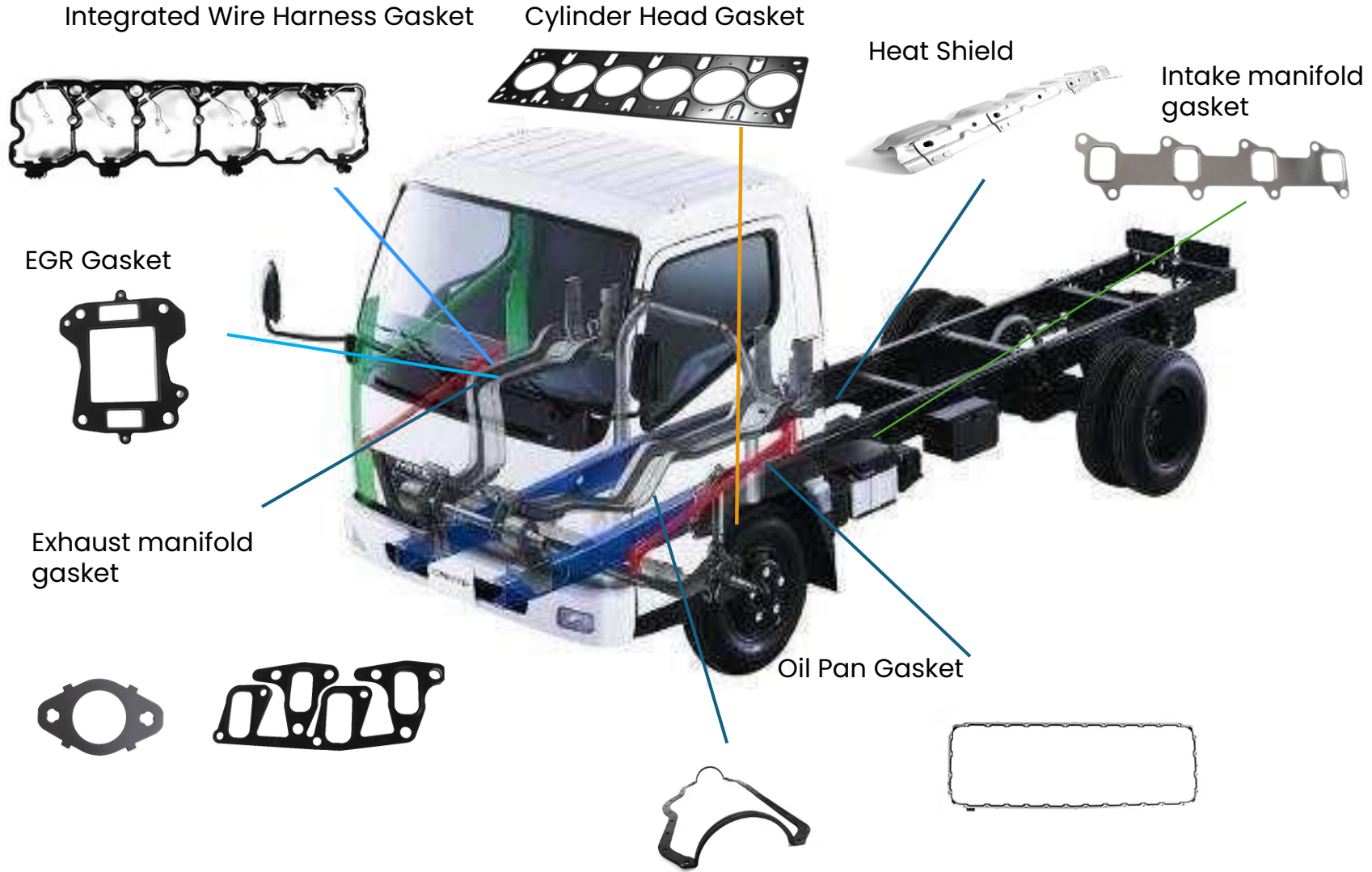

Product Profile - Forging Division

Off Highway - Components

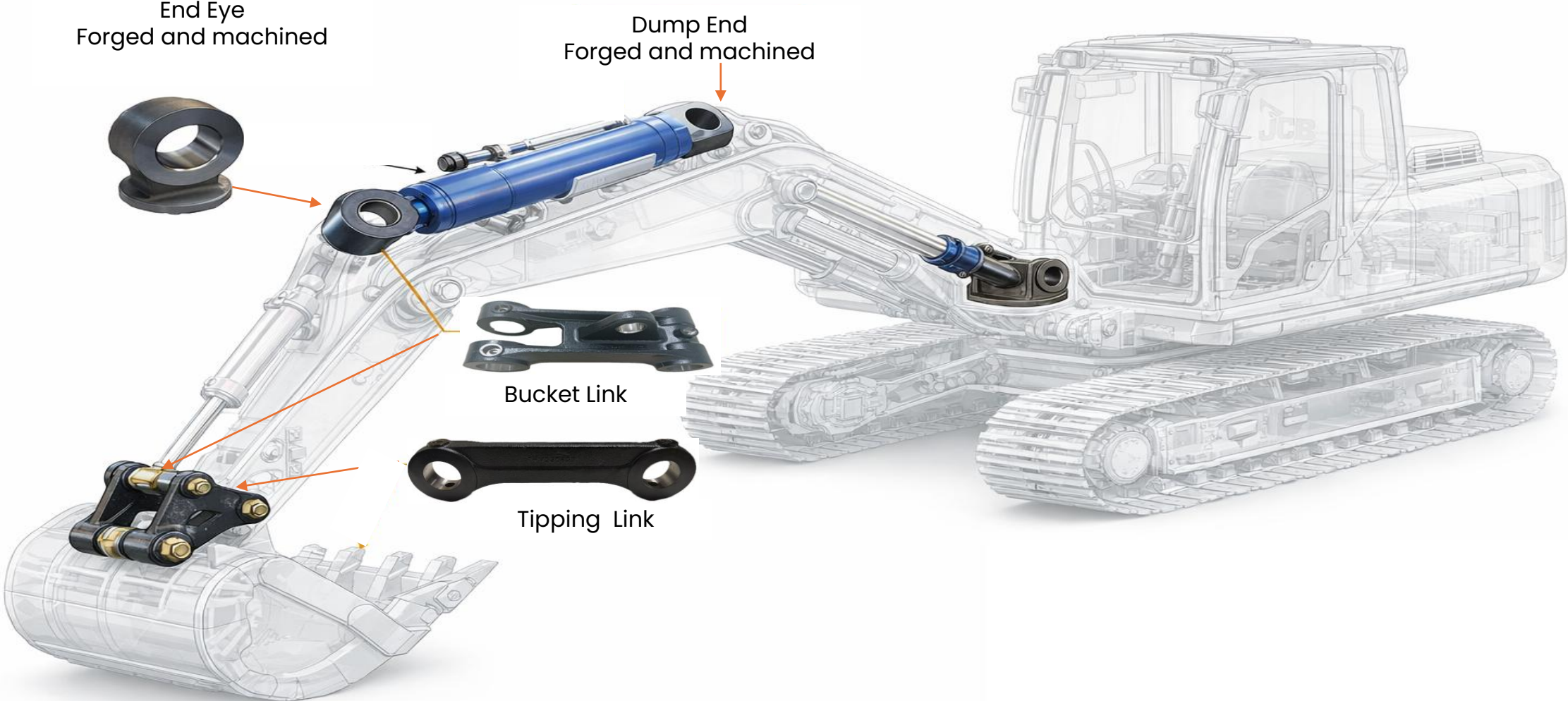

Product Profile - Forging Division

Commercial Vehicles - Components

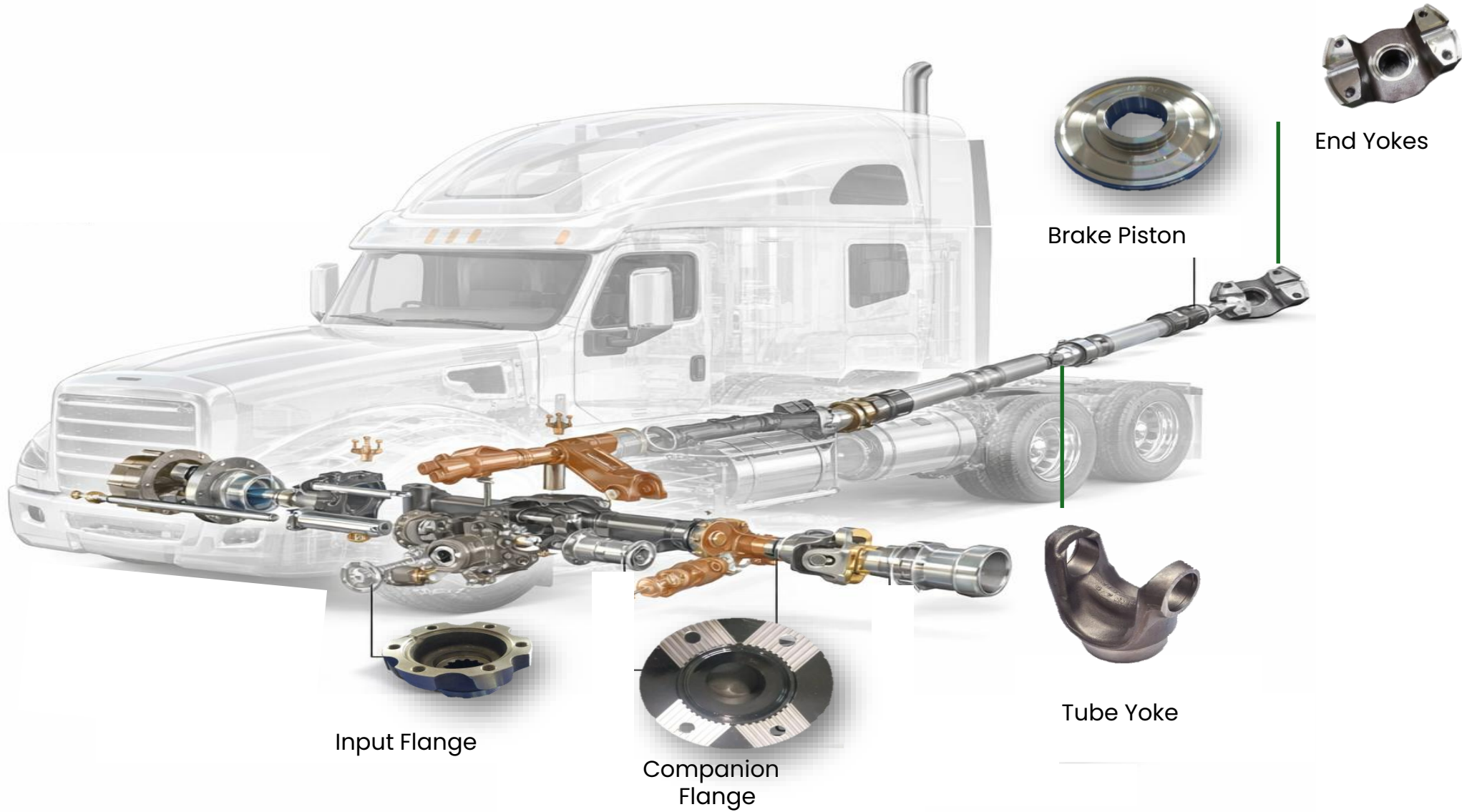

Product Profile - Forging Division

Passenger Vehicles - Components

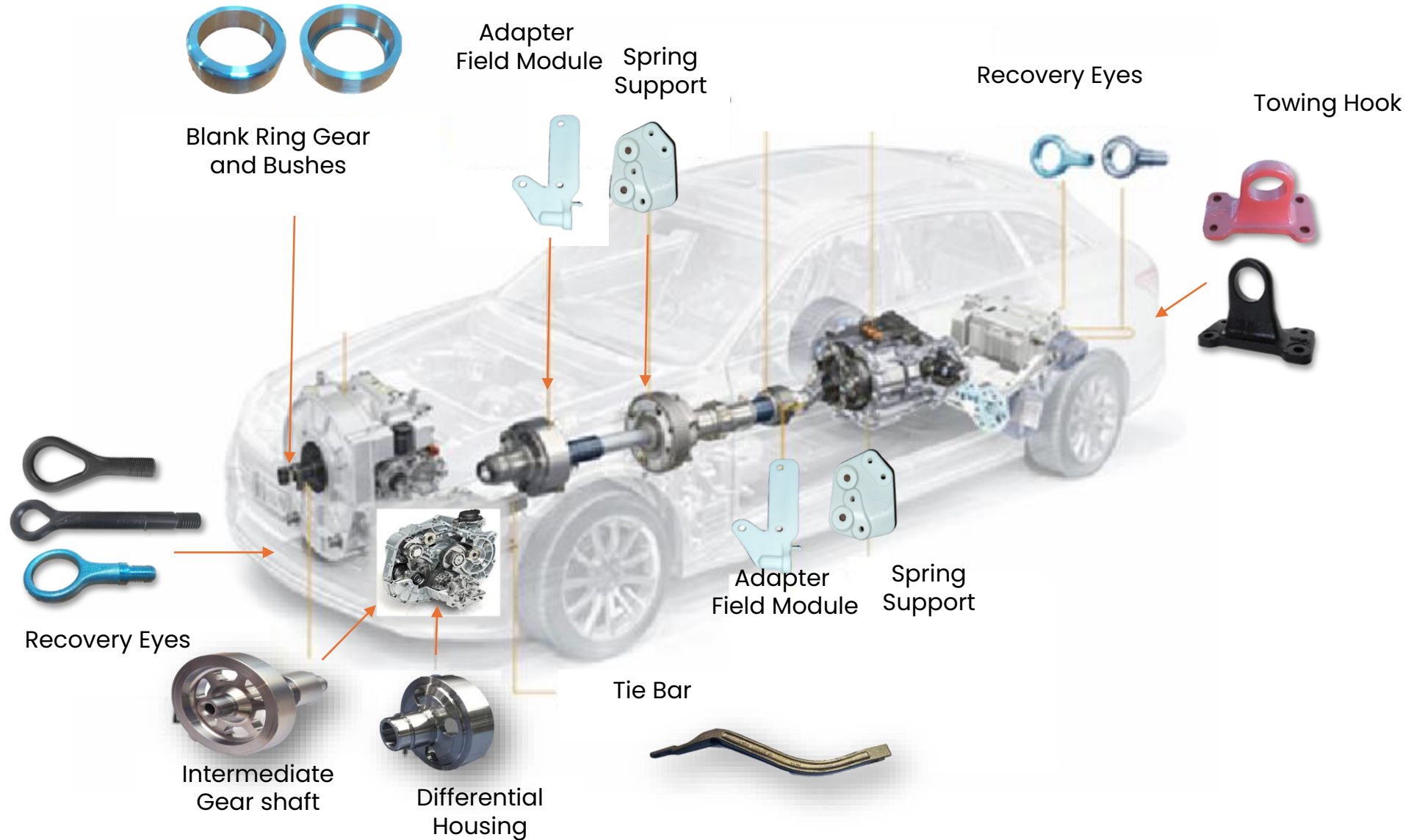

Product Profile – MTCS (1/2)

Passenger Vehicles – Chassis & BIW
Components

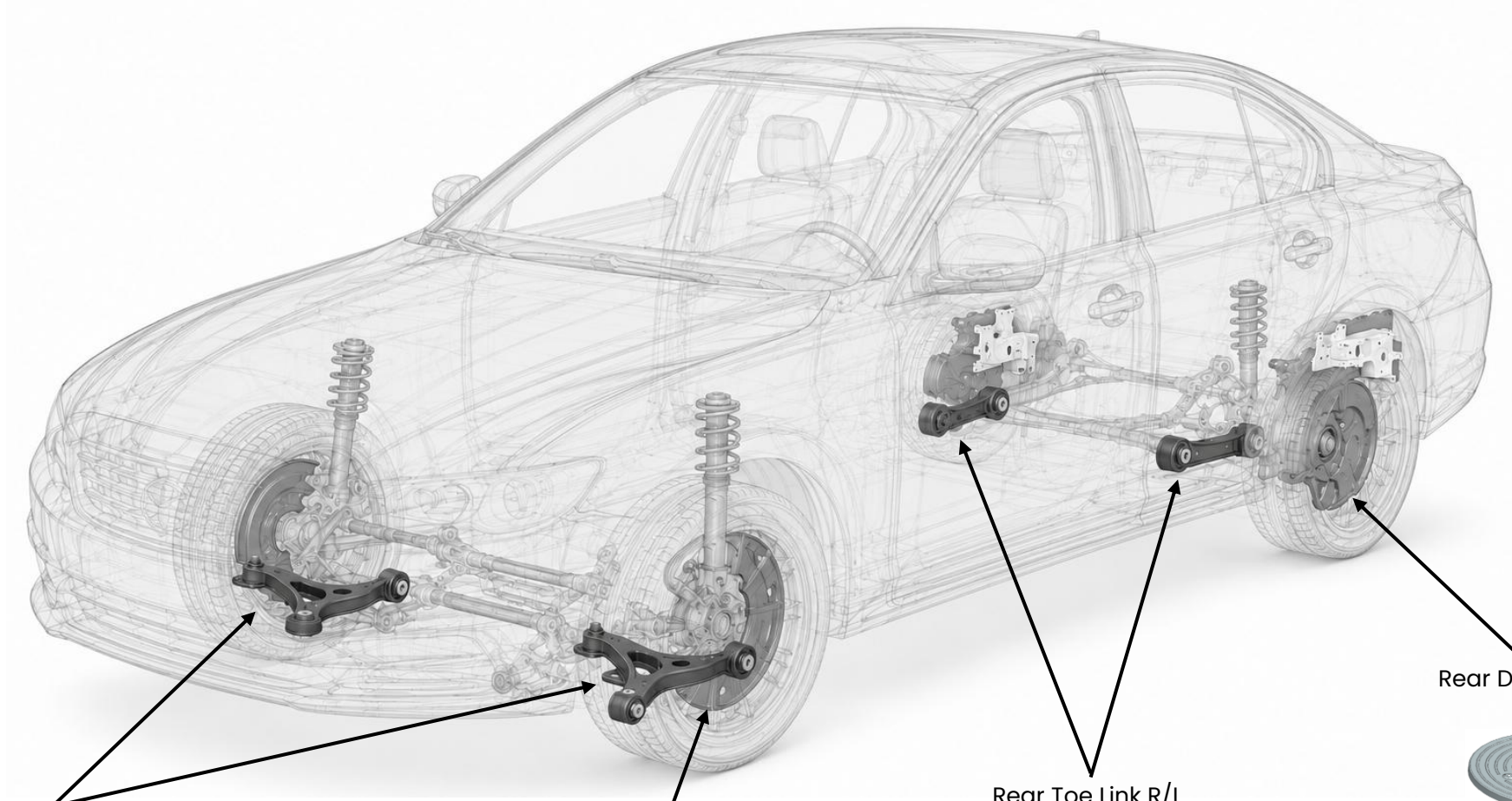

Arm Assy Front Suspension R/L

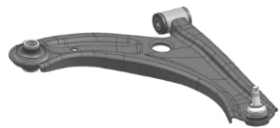

Front Dirt shield



Rear Toe Link R/L



Rear Dirt shield



Product Profile – MTCS (2/2)

Passenger Vehicles – Chassis & BIW
Components

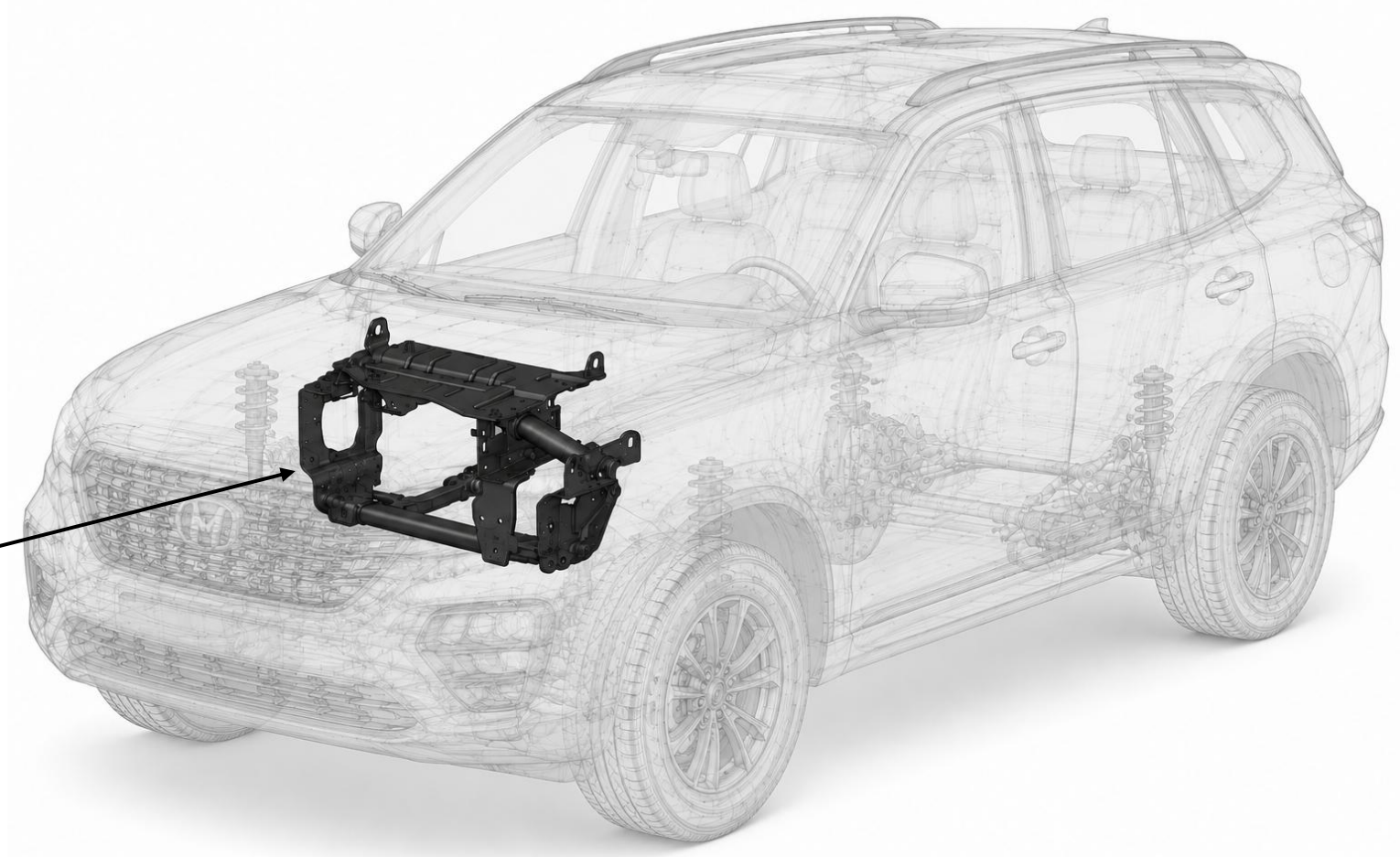

Front Cradle for EV



Product Profile – TMR

Variation control parts in Passenger Car

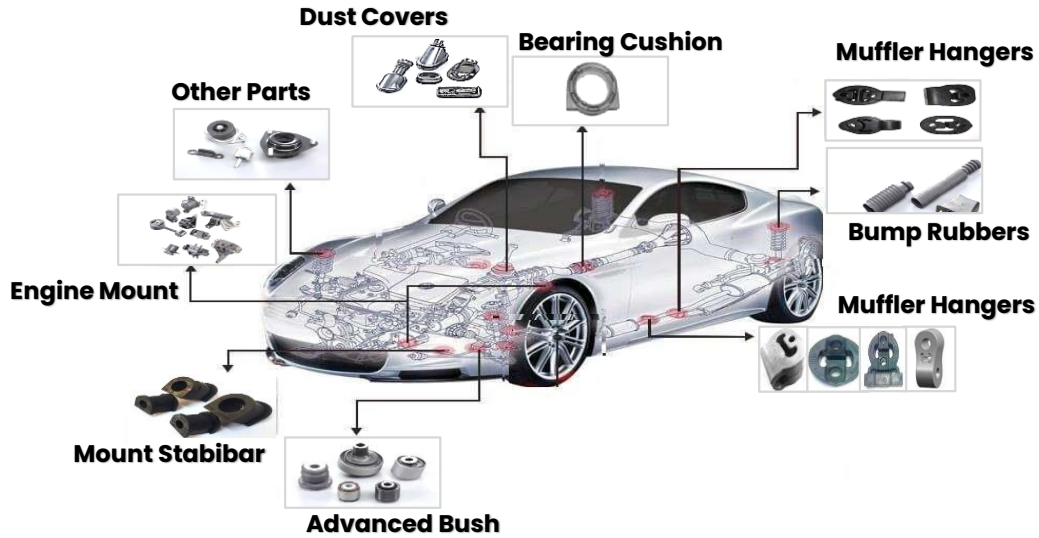

Parts for Truck

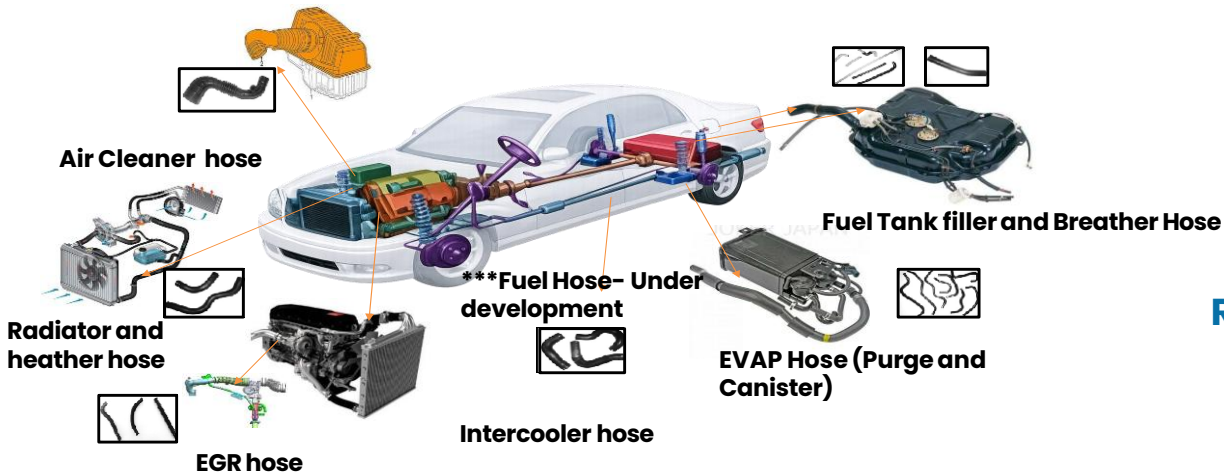
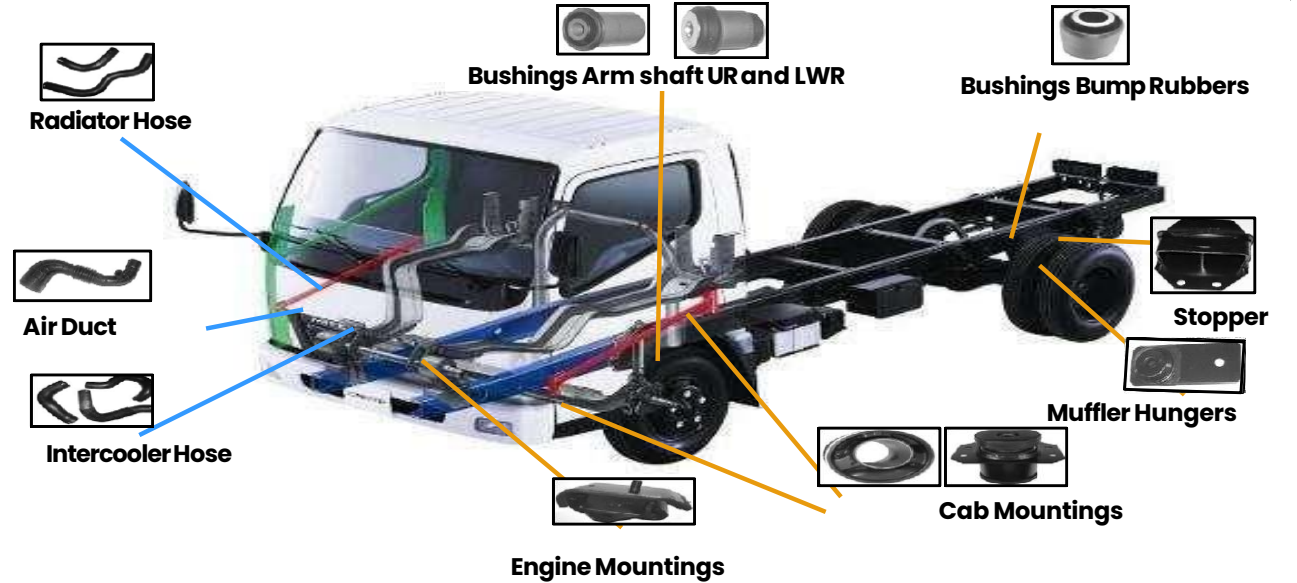

Rubber Hose in Passenger Car

Annexures

Strong Board of Directors

Visionary Promoter team with Decades of Industry Experience



Mr. Naresh Talwar

Non Executive Director



Mr. Umesh Talwar

Chairman



Mr. Varun Talwar

*Vice Chairman &
Managing Director*



Mr. Anuj Talwar

Managing Director



Mr. Navin Juneja

Director & Group CFO



Mr. Vidur Talwar

Non-Executive Director

Diverse and Experienced Independent Board bringing Domain Expertise



Mr. Deepak Jain

*Independent
Director*



Mr Rakesh Vohra

*Independent
Director*



Mr. Tarun Singhal

*Independent
Director*



Mrs. Priyanka Gulati

*Independent
Director*



Mr. Ajay Kumar Vij

*Independent
Director*

Executive Management Team

Mr. Ashish Gupta CEO

- He holds a BE degree and has over 35 years of experience with manufacturing companies in India, Europe & CIS

Mr. Manish Khanna Chief Financial Officer

- A Qualified CA and MBA
- He has over 18 years of experience with LeeBoy India Constructions, Doosan Infracore, Escorts Construction Equipment and Amforge Industries

Mr. Suresh Sharma President – Gaskets Division

- He is an engineer and MBA (Operations)
- He has over 26 years of experience in the Auto Components sector and has worked with Munjal Showa, Endurance, JBM Auto and Omax Auto

Mr. Vivek Singh President – Forging Division

- He holds a Mechanical Engineering degree and has a rich experience in manufacturing of more than two decades in varied sectors including Auto & Auto component, Railway signaling & Telecom, Geo Info Systems & IT technology and Powertrain.

Mr. Masaru Morisaki Director – TMR

- He has rich experience in Auto Industry and is actively overseeing Company's performance, participating from Marugo Rubber Industries, Japan.

Mr. Vineet Gupta Business Unit Head – MTCS

- He holds a Master Degree in Business Administration and bachelor degree in Mechanical engineering and has over 23 years of experience. He was earlier Head of Business Development and Supply Chain of Marelli Talbros Chassis systems Pvt Ltd.

Mrs. Seema Narang Company Secretary

- She has over 30 years of experience in the secretarial department and has worked with Whirlpool of India and Aksh Optifibre Limited

Awards & Recognition

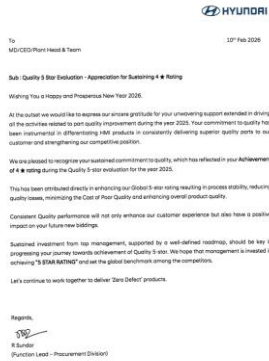

Appreciation for sustaining 4 star rating



Zero defect performance award 2023-24



Implementation of occupational health & Safety Management System



ACMA Excellence Award



JCB – Export Excellence



CCQC - 2025



Kirloskar New Product Development Award



Kaizen Award by CII



EPEC – Export Excellence Award



Recognition for Achieving

Historical Consolidated Profit & Loss Statement

Particulars (Rs. Crores)	FY26	FY25	FY24
Revenue from Operations	870.0	827.1	778.3
Other Income	18.5	17.7	12.6
Total revenue from Operation	888.5	844.7	790.9
Raw Material	451.0	429.4	422.5
Employee Cost	99.5	92.3	81.1
Other Expenses	183.0	175.9	160.0
EBITDA	155.1	147.3	127.2
EBITDA Margin	17.5%	17.4%	16.1%
Depreciation	32.7	31.9	25.9
EBIT	122.4	115.4	101.3
EBIT Margin	13.8%	13.7%	12.8%
Finance cost	13.2	13.7	13.3
Share of Profit from JVs	0.0	17.7	16.2
Profit before Tax (Before Exceptional Items)	21.7	119.4	104.2
Tax	130.9	25.0	21.3
Profit After Tax (Before Exceptional Items)	26.8	94.4	82.9
PAT Margin %	11.7%	11.2%	10.5%
Exceptional items	0.0	0.0	42.5
Tax on Exceptional Items	0.0	0.0	15.4
Profit After Tax	104.1	94.4	110.0
PAT Margin %	11.7%	11.2%	13.9%

Historical Consolidated Balance Sheet

ASSETS (Rs. Cr.)	Mar-26	Mar-25	Mar-24
Non-current assets			
Property, plant and equipment	224.9	217.7	209.0
Capital work in progress	21.7	22.7	7.3
Investment property	2.3	2.5	2.7
Intangible assets	0.4	0.3	0.6
Investments accounted for using the equity method	84.3	64.0	47.4
Financial assets			
Investments	162.2	145.4	138.4
Other financial assets	7.2	3122	70.7
Current Tax Assets	1.5	1.7	3.3
Other non-current assets	4.4	3.5	6.7
Non-Current Assets	509.1	489.0	486.0
Current assets			
Inventories	145.9	125.9	126.8
Financial assets			
Trade receivables	282.2	245.7	210.3
Cash and cash equivalents	35.8	14.8	2.4
Bank balances other than Cash and Cash equivalents	78.0	48.2	2.8
Loans	0.5	1.6	2.7
Other financial assets	1.6	1.9	1.6
Other current assets	32.1	23.5	24.2
Current Assets	576.0	461.5	370.8
TOTAL - ASSETS	1085.1	950.5	856.7

EQUITY AND LIABILITIES (Rs. Crs.)	Mar-26	Mar-25	Mar-24
Equity			
Equity Share capital	12.3	12.3	12.3
Other equity	730.5	620.3	524.8
Shareholders' Funds	742.9	632.6	537.2
LIABILITIES			
Non-current liabilities			
Financial liabilities			
Borrowings	2.0	3.6	3.4
Lease Liabilities	6.0	8.0	9.9
Other financial liabilities	0.2	0.5	0.3
Provisions	2.8	2.7	2.1
Deferred tax liabilities (net)	37.4	34.7	33.5
Other non-current liabilities	0.4	0.2	1.1
Non-Current Liabilities	48.8	49.6	50.2
Current liabilities			
Financial liabilities			
Borrowings	72.9	79.5	82.8
Lease Liabilities	2.8	2.7	2.6
Trade payables	199.4	169.6	167.7
Other financial liabilities	11.5	8.0	8.6
Other current liabilities	5.6	7.2	6.3
Provisions	1.3	1.4	1.3
Current tax liabilities (net)	0.0	0.0	0.0
Current Liabilities	293.4	268.3	269.3
TOTAL - EQUITY AND LIABILITIES	1085.1	950.5	856.7

Historical Consolidated Cash Flow Statement

Particulars (Rs. Crores)	FY26	FY25	FY24
PBT	130.9	119.4	146.7
Adjustments	13.7	16.7	-23.5
Operating profit before working capital changes	144.6	136.2	123.2
Changes in working capital	-32.8	-32.3	-33.7
Cash generated from operations	111.9	103.8	89.4
Direct taxes paid (net of refund)	-27.2	-23.8	-22.7
Net Cash from Operating Activities	84.7	80.0	66.7
Net Cash from Investing Activities	-35.9	-44.7	-51.8
Net Cash from Financing Activities	-27.8	-22.9	-17.9
Net Change in cash and cash equivalents	21.0	12.5	-2.9
Opening Cash Balance	14.8	2.4	5.3
Closing Cash Balance	35.8	14.8	2.4



THANK YOU !

For further information, please contact:

Company:



Talbro's Automotive Components Limited
CIN: L29199HR1956PLC033107

Ms. Seema Narang
seema_narang@talbro's.com

www.talbro's.com

Investor Relations Advisors:

SGA Strategic Growth Advisors

Strategic Growth Advisors Pvt. Ltd.
CIN: U74140MH2010PTC204285

Mr. Deven Dhruva/ Ms. Prachi Chhugani
deven.dhruva@sgapl.net/prachi.chhugani@sgapl.net

Tel: +91 98333 73300 / +91 89492 92029
www.sgapl.net

A graphic consisting of a grid of blue dots of varying sizes, arranged in a pattern that tapers to the right. Below this graphic is the text 'Move the Auto World' in a large, bold, sans-serif font. 'Move' is in blue, 'the' is in a smaller white font, and 'Auto World' is in white.

Move the
Auto World